

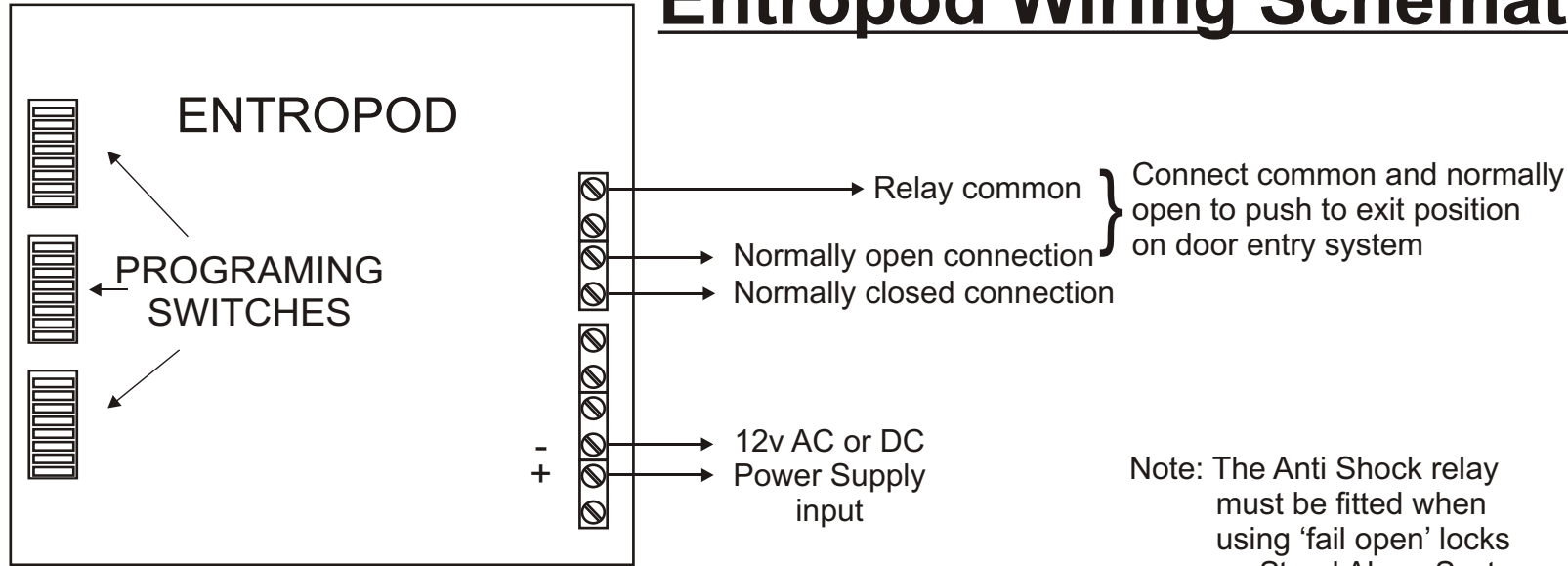

Entropod Wiring Schematic

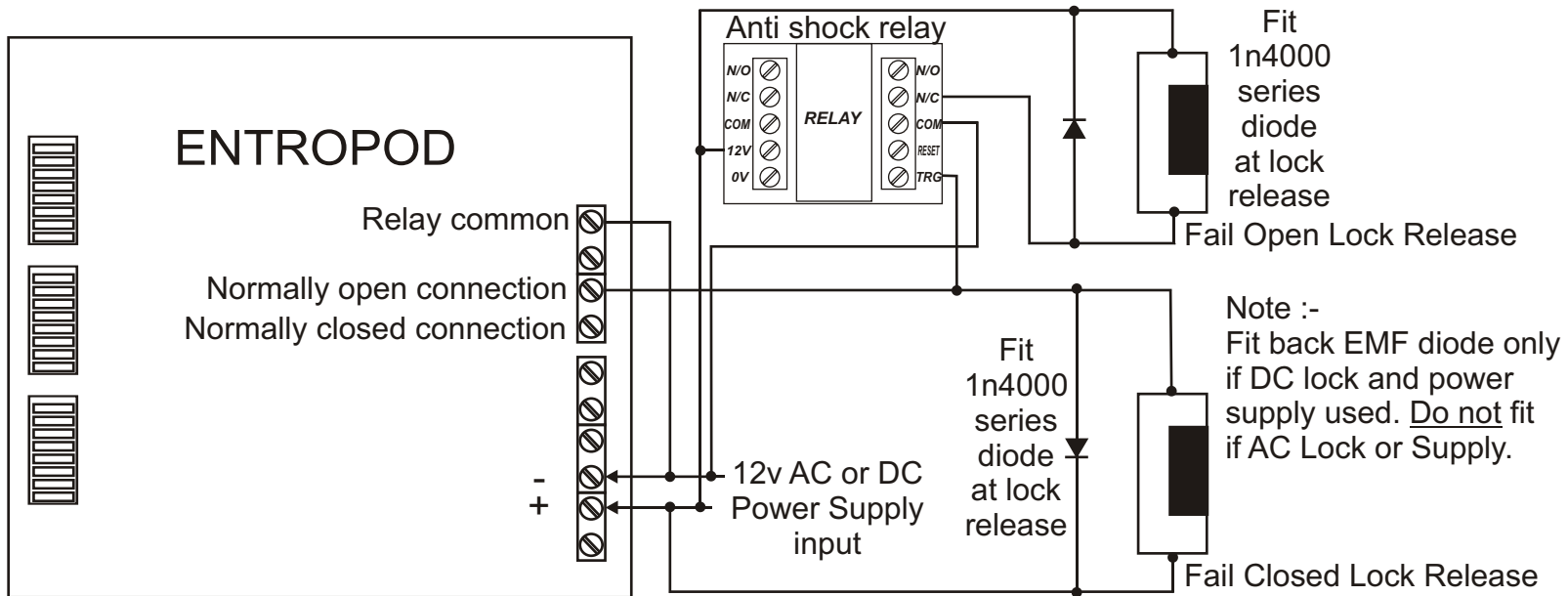

Example Stand - Alone Wiring



DATE: 3/5/2006	DRG.NO.	DESC.	DRAWN BY: V.A.TURNER
 ENTROTECLTD 1 KELVIN SQ. HOUSTON IND. EST. LIVINGSTON WEST LOTHIAN. EH54 5PF TEL: 01506 441100 FAX: 01506 442400	WIRING SCHEMATIC FOR ENTROPOD ACCESS CONTROL	WIRSC0799/049/1	CHECKED BY:
ALL CABLES TO BE KEPT WELL AWAY FROM MAINS VOLTAGE CABLES. PLEASE CONSULT OUR INSTALLATION GUIDELINE SHEET OR CONTACT OUR TECHNICAL DEPT. FOR ADVICE ON 01506 441100.		TESTED BY:	
IMPORTANT.			